

PLAN VIEW

SPECIFICATIONS

5000PSI WITH SUPER PLASTICIZER

BOTTOM AND SIDES ARE REINFORCED WITH 6X6X10 GAUGE WIRE

TOP IS REINFORCED WITH 1/2" GRADE 60 REBAR ON 12" CENTERS

POLYLOK III PRESSURE RATED RUBBER SEALS AVAILABLE UPON REQUEST

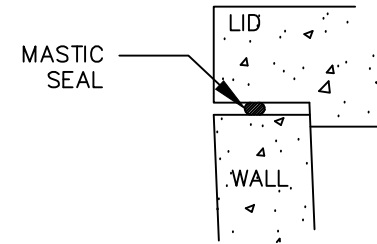

SEAL DETAIL

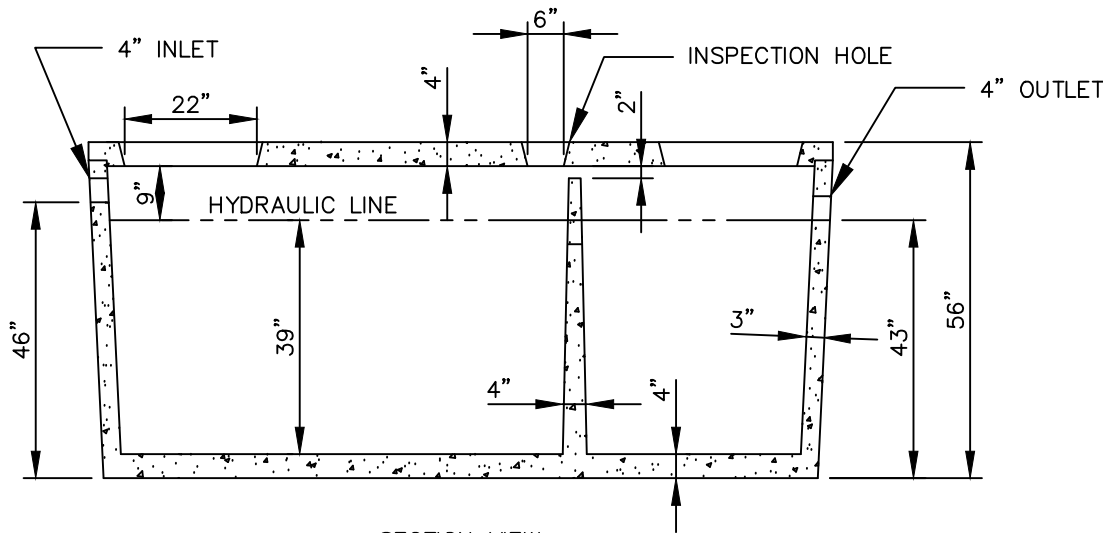

SECTION VIEW

THIS DOCUMENT MAY NOT BE DISTRIBUTED, MODIFIED, ALTERED, OR REPRODUCED IN WHOLE OR IN PART WITHOUT THE PRIOR WRITTEN PERMISSION OF MARYLAND CONCRETE SEPTIC TANK INC.

REVISION SIGNOFF

Number	Date	Initial
1		
2		
3		
4		
5		
6		
7		
8		

Maryland Concrete Inc.

1250 GALLON 2 COMPARTMENT
SEPTIC TANK

DRAWN: JMH 6/10/13
CHECKED: TLG
SCALE: 3/8" = 1'

No. MC013

DATE	REVISION DESCRIPTION	DESIGNER/CHECKER
9/4/13	ISSUED FOR CONSTRUCTION	JMH / TLG